

QUEST<sup>®</sup>  
AIRCRAFT

# KODIAK<sup>®</sup>

RUGGED | RELIABLE | VERSATILE

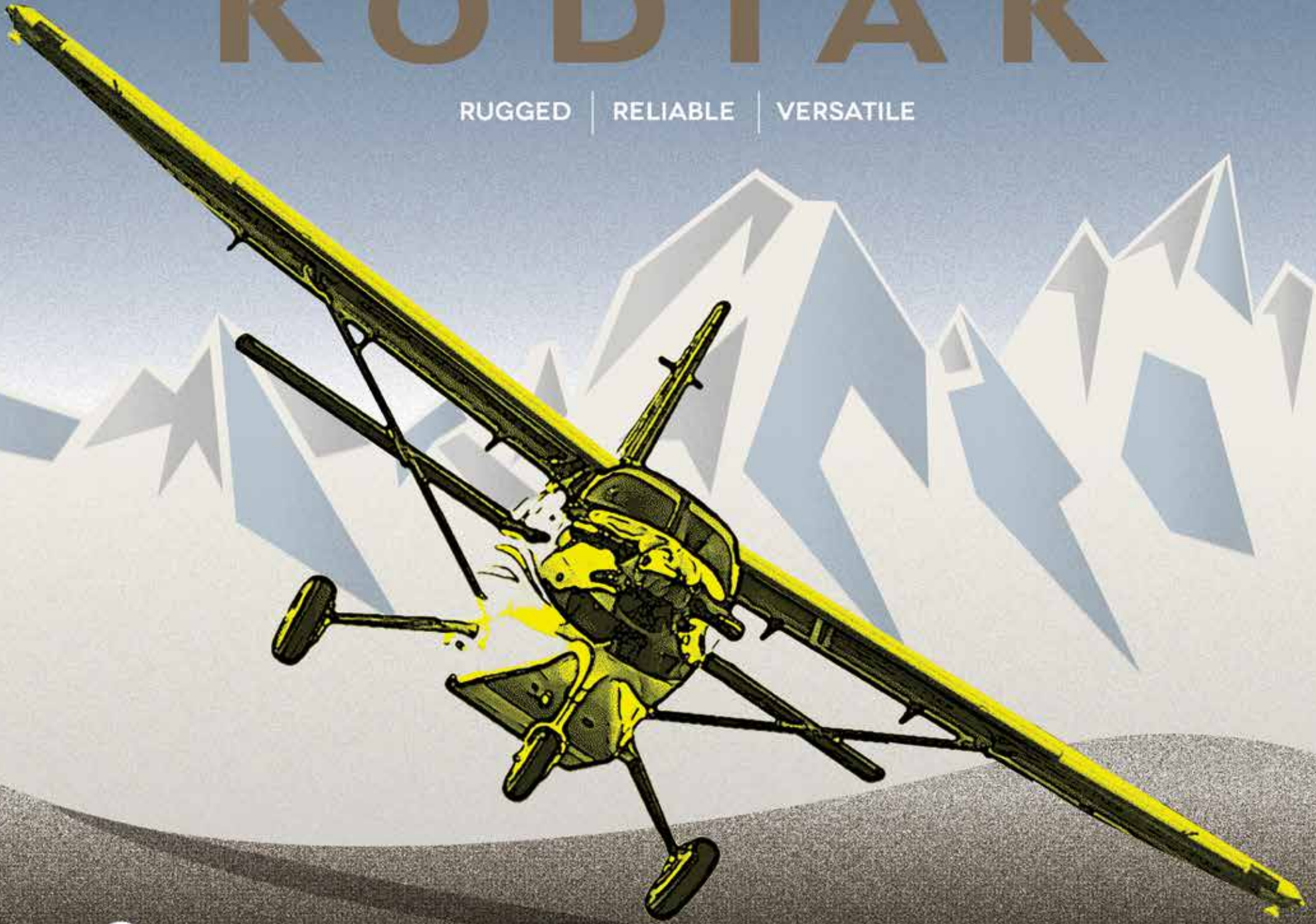

LEG 4

1132  
NM

THE JOURNEY STARTS HERE

— THE —  
**KODIAK**<sup>®</sup>

THE  
BRIDGE  
BETWEEN  
HELICOPTER  
AND  
BUSINESS JET.

A smart aircraft designed for the 21st century.  
Built tough and safe for extreme missions.  
Comfort, capacity and economy for business or personal use.  
Only one pilot needed. A dream to fly.  
Many missions. One aircraft.



MADE BY HAND IN SANDPOINT IDAHO

THE KODIAK'S RUGGED ALUMINUM CONSTRUCTION COMBINES SUPERIOR STOL PERFORMANCE AND HIGH USEFUL LOAD. IT OFFERS PROVEN RELIABILITY WITH THE PRATT & WHITNEY PT6A TURBINE ENGINE, HAS THE ABILITY TO LAND AND TAKE OFF FROM UNIMPROVED SURFACES AND IS CAPABLE OF WORKING OFF FLOATS WITHOUT STRUCTURAL UPGRADES.



## IMPRESSIVE RANGE, ECONOMY AND PERFORMANCE

FOR JUST ABOUT ANY DESTINATION IN THE WORLD, THE KODIAK CAN GET YOU THERE. CRUISING AT 12,000 FEET AT 174 KTAS, IT HAS A MAX CRUISE RANGE OF 1005 NM. THAT EQUATES TO OVER 5.8 HRS WITH FUEL CONSUMPTION AT 48 GPH.



## THE QUEST: TO DO GOOD, TO DO BETTER.

### THE RESULT: THE AMAZING KODIAK 100 ALL-WEATHER, ROUGH-TERRAIN WORKHORSE.

The history of aviation is a never-ending story of inspiration and innovation, to address a challenge and make a better plane. This is what brought three aviation veterans together. These founders of what would become Quest Aircraft identified a need for a sturdy and powerful STOL aircraft that could deliver humanitarian aid to the most remote places on the planet.

Sure, there were other venerable aircraft that had been doing this type of job well, but these planes were designed half a century ago. A lot has changed, like light weight, yet ultra strong materials, integrated avionics, variable airfoils, raw power, fuel efficiency and, most importantly, safety. The rigors of getting into and out of the toughest locations over and over required a rethink. In addition, they had to keep the price and the maintenance costs down. Some service may have to be done in a muddy field by the pilot-mechanic. That left more NGO money for aid, not aircraft. The result is the amazing Quest Kodiak 100, a rugged 10-seat turboprop that can takeoff in under 1000 feet fully loaded, fly for a thousand-plus miles, land on any reasonably safe spot and get back again.

The Kodiak began as the brainstorm of an innovative aircraft designer and joined by a veteran aviator, who had spent a lifetime flying for humanitarian organizations. The designer and the pilot both understood the mission: fly into some of the roughest terrain, hot or high, with critically needed doctors and supplies and get out safely . . . with the plane. Their passion attracted NGO investors and an experienced administration advisor, the former CEO of Alaska Airlines. By 2007 they had a certified plane, a long list of orders and a world of missions ahead.

In the process they also founded a family of dedicated techies, craftsmen and administrators in the tiny hamlet of Sandpoint Idaho, one of the most beautiful but unlikely sites for an aircraft manufacturer. There was clearly more than money involved. The mission to do good also meant do good by their employees and their town. With that they established an enterprise that can only be compared to a classic boatbuilding shop in Maine, where skilled American craftsmen shape aluminum, not wood, into modern boats of the air.

It did not take long for the aviation community to take notice. If the Kodiak could do that, what else could it do? And that's when Sam Hill entered the scene. Sam is an ATP pilot, a master of aviation business and, today, CEO of Quest Aircraft. His vision was to expand the market for the Kodiak across user groups and around the world while maintaining honesty, integrity and a commitment to build the best, most versatile aircraft in its class. That strategy has led to an ever-expanding list of customers including operators of corporate fleets, air-taxi services, the national parks, owner-operators, backcountry outfitters, parachute clubs, scientific surveyors, ranchers, air ambulance services . . . and the list just keeps expanding not only across customer categories, but worldwide.

In 2015, Quest had sealed a deal with Japan's Setouchi Holdings, a global entity with roots in shipbuilding, transportation and related industries. With their Japanese passion for precision and quality, Quest could not have found a better partner. The mission to do good and do better has now led to a world market including Europe, South America, Africa, Asia and Australia. Not bad for a little company with the vision to think big.

An aerial photograph of a Kodiak aircraft, a high-wing, three-engine turboprop plane, flying over a large body of water. The aircraft is dark blue and white, with the word "KODIAK" visible on the nose. It is flying towards the viewer and slightly to the left. In the background, a smaller blue and white seaplane is visible, flying in the same direction. The water is a deep blue, and there are some small islands or peninsulas visible in the distance. The sky is clear and blue.

In an industry focused on the time between takeoff and landing, we are more concerned about where the Kodiak will take you, what it enables you to do once there and the remarkable ability to get you back.

Your choice of aircraft should enable your ambitions or meet your company goals. Whatever they may be, the Kodiak is the right tool for the job.

THE KODIAK CAN TAKE OFF IN UNDER 1,000 FEET AT FULL GROSS WEIGHT OF 7,255 LBS AND CLIMB AT OVER 1,300 FEET PER MINUTE.





## GETTING DOWN TO BUSINESS OFTEN MEANS GETTING THERE FASTER.

THE DEPENDABLE ALL-WEATHER BUSINESS AVIATION SOLUTION.

The world of business aviation offers many choices. Executive jets. Pressurized turboprops. Twins. They all come at a price. But there is an alternative: The Quest Kodiak with three choices of interior to match your business needs. Outfitted for comfort and focused on safe, affordable 1,100 mile hops, the Kodiak makes it possible to make frequent trips to remote worksites or even eliminate field offices. The Kodiak fills the gap between long haul jets and a long grueling drive. Unlike most of the executive aviation options, the Kodiak does not need a paved runway, and it can be flown by a single pilot.

The Kodiak can be a special option for your charter flight or business operations. There is the option of the very roomy and upgraded 6-passenger Summit interior, while maintaining the payload capacity and climb performance that makes the Kodiak famous worldwide. The Summit interior includes beautiful leather and wood appointments. The cabin is fully air conditioned with shaded windows and individual USBs and air control. There is ample room for baggage and equipment both in the body of the plane or in the optional pannier.

With direct operating costs that are less than most piston twins, the Kodiak allows you to spend more time flying and generating income. Modern avionics and turbine reliability bring comfort and reassurance to your passengers while reducing downtime for maintenance and lost productivity. It is a great combination of a being a cost-effective solution for local and regional flights and the capability to take you and your guests on those unique adventure trips with all their luggage and gear. And let's not forget about the flying experience. The Kodiak typically flies under 12,000 feet giving passengers an unprecedented view of the world beneath them. Unlike a jet at Flight Level 300, passengers enjoy breathtaking vistas through large windows.



WITH ITS COMFORTABLE INTERIOR,  
AMPLE STORAGE AND ECONOMY,  
THE KODIAK FILLS THE GAPS IN  
YOUR CORPORATE FLEET, FREIGHT  
OPERATION OR CHARTER SERVICE.



TIMBERLINE INTERIOR



TUNDRA INTERIOR

## INTERIOR PACKAGES

### SUMMIT

The top-of-the-line Summit interior offers club seating, cabinetry, and carpet that allows you to conduct a business meeting in comfort on the way to the construction or project site. This interior also makes the Kodiak great for family trips! A true example of rugged refinement, Summit features individual headset jacks, oxygen, light and ventilation with charging ports for your portable electronic devices, so you are entertained or productive while on the go.

### SUMMIT SEATS DESIGNED BY MILLENNIUM CONCEPTS

- All-leather, fully adjustable seats
- Full recline function so you can stretch out and relax
- Individual tracking systems for additional leg room at each seat
- Adjustable headrests
- Fold down arm rest
- Comfortable safety harness - three point restraint that retracts
- Easy access to microphone/headphone jacks and oxygen

### OTHER AMENITIES

- Individual storage pockets in the sidewall at each seat
- Cupholders in both the cabin and cockpit
- Overhead PSU air and lighting units at each seat
- Club seating with two fold-out tables (one on each side)
- Each table is concealed in the sidewall and easily deploys and stows
- Two cabinets with a combined 2.5 cubic feet of space
- Cabinet features include removable ice bins, thermos provisions and vertical storage for the POH, maps and other materials
- Optional sixth cabin seat for additional seating



### TIMBERLINE

A step up from the Tundra, the Timberline offers all the functionality of the Tundra, but with upgrades like carpeted interior, faux leather accent panels, seat storage pockets, and cup holders, you'll be flying in style. Timberline seats have additional bolstering for added comfort, and the removable carpet provides extra comfort, warmth, and soundproofing. If you're looking for the ruggedness of the Kodiak, but aren't willing to sacrifice comfort, Timberline is the interior for you.

The Interior Package comes in warm beige or cool gray and includes your choice of seat color and lower interior panel color. The standard Timberline interior comes with:

- 2 Timberline crew seats
- 4 Timberline passenger seats
- Slip-resistant flooring
- Removable carpet
- 8 Passenger headset jacks
- 8 Passenger PSU vents and reading lights
- Storage pockets in the sidewall beside each seat
- Cupholders in both the cabin and cockpit
- Decorative arm ledge
- Full cabin ventilation control system
- 2-place oxygen system for crew

### TUNDRA

The Tundra base interior is lightweight, yet it can withstand the heavy use typically seen in charter operations that carry a combination of passengers and freight. The leather seats are easily removed (about 30 seconds each) and stowed for effortless conversion between passengers and freight. The floor is protected with a layer of rubber compound which provides a rugged anti-skid surface. Passenger Service Units provide fresh air vents and reading lights at each of the 8 passenger stations. Headset jacks are located at each passenger seat to allow everyone on board access to the aircraft's intercom system.

The Interior Package comes in warm beige or cool gray and includes your choice of seat color and lower interior panel color. The standard interior comes with:

- 2 Tundra crew seats
- 4 Tundra passenger seats
- Slip-resistant flooring
- 8 Passenger headset jacks
- 8 Passenger PSU vents and reading lights
- Full cabin ventilation control system
- 2-place oxygen system for crew



# BEFORE YOU TAKE OFF, LET'S HAVE A FRANK TALK ABOUT SAFETY.

## **INNOVATIVE WING DESIGN PROVIDES EXTRA MARGIN OF SAFETY**

The Kodiak's patented "discontinuous leading edge" wing design yields performance at all flight envelopes. When most airplanes would stall, the Kodiak continues to fly. When most airplanes would spin, the Kodiak allows the pilot full aileron control, providing an unprecedented level of safety in an airplane of this size.

## **ENGINE AND POWER TO GET YOU UP AND OUT QUICKLY**

The Pratt & Whitney PT6A is a synonymous with reliability. The -34 variant is the most proven & most economical of the bunch. The Kodiak has a power to weight ratio of 9.67lbs/horsepower. 20% better than the closest competition.

## **TOUGH GEAR FOR ROUGH SITUATIONS**

Robust, class-leading fixed landing gear with large tires gives peace of mind even on the roughest terrain. The Kodiak's landing gear was also designed with muddy conditions in mind, certified with a lower tire PSI to "float" on the surface and not get bogged down.

## **ENGINEERED AND BUILT STRONG**

They don't make them like the used to? Well, the Kodiak breaks that mold. It's built like they used to be — with modern improvements. Built to withstand rigorous abuse and keep flying, the Kodiak is the modern airplane that will still be flying in 50 years - built to the quality standards of another time.

## **FLY SAFER IN ALL-WEATHER CONDITIONS**

A larger coefficient of lift ( $C_L$ ) and modern TKS anti-ice gives the Kodiak an unbelievable margin of safety and performance in even the worst weather conditions.

## **GARMIN® GFC700 AUTOPILOT: REDUCES WORKLOAD, ENHANCES SITUATIONAL AWARENESS**

Fully integrated into the G1000 Flightdeck, the GFC700 is a three axis, attitude based autopilot. A fully digital, dual-channel flight control system with unprecedented levels of sophistication and safety in this class of airplane. Fly it, to believe it.

## **PUT SIMPLY, THE ONLY CATEGORY THAT MATTERS IS SAFETY. YOU WON'T FIND THESE FEATURES ON COMPETITORS DESIGNED IN THE LAST CENTURY.**

The Kodiak 100 is certified to modern 21st century FAA standards. The part 23-55 amendments, applied in 2002, are the product of decades of accident investigations, which increases safety.

- There are over 1000 additional safety enhancements the Kodiak has, which our competition does not have. This is due to our modern 2007 certification vs. their decades old certification.
- The Kodiak's seats were dynamically sled tested to 26g's. Older regulations only required seats to be drop tested to 9g's. This old testing method was found unrealistic for measuring survivability and changed in 1988.
- Flammability requirements were increased to include the entire airframe (firewall to cargo), not just in passenger areas. The Kodiak meets and exceeds the latest flammability regulations.
- The Kodiak had to be tested to withstand the often harmful effects of a lightning strike. If lightning is near by, you can rest assured knowing the Kodiak won't lose power to those all important avionics systems to get you away from the storm.
- Amendment 55 standards require a demonstration of a 50 ft. post-takeoff engine failure, which the Kodiak passed with flying colors. Older regulations did not require a this for a type certificate.

These items and more make the Kodiak one of the safest airplanes manufactured today.





## SKYDIVING BOITUVA BRAZIL

THREE ENTERPRISING BRAZILIANS LAUNCH A PARACHUTE SCHOOL AND JUMP CLUB WITH THE VERSATILE KODIAK.

Boituva is home to Brazil's National Skydiving Center (Centro Nacional de Paraquedismo) and located about 116 kilometers from São Paulo. Queda Livre Paraquedismo, which is both a jump club and parachuting school, is one of the best-known parachuting services in the area. Their airplane of choice is the ultra-modern Kodiak that can deliver jumpers to 12,000 feet in minutes. Think of it as an elevator to the sky. This unique performance increases turn-around speed, safety and profits.

The incredible versatility of the Quest Kodiak is no accident. The Kodiak was engineered from the start to be a multi-use platform that can be easily adapted to specialized needs. The ability to make short take off and landings from unimproved strips combined with a powerful engine and strong gear makes this aircraft ideal for many business needs. All it takes is a leap of imagination.



PILOT



15 JUMPERS

12,000 FT IN 9 1/2 MIN  
4 SKYDIVER LOADS PER HOUR =  
INCREASED FUN & REVENUE



## THE EYE IN THE SKY BOTSWANA AFRICA

ADVANCED ISR ON THE KODIAK PLATFORM CAN PROTECT WILDLIFE AND THE TOURISM ECONOMY

Throughout the world, countries and companies are making use of the latest in airborne ISR technologies to assess and protect resources. With its long loiter time, the Kodiak is the perfect platform to conduct scientific surveys, support archeological work and study wildlife migrations without the interference of low-flying helicopters. Power companies use advanced ISR to evaluate resources. Parks and forestry services use it to measure the health of public lands and water resources and to direct fire suppression operations. ISR has also become increasingly important to law enforcement, extending that "thin red line" of deterrence.

In Botswana, the Ministry of Environment, Wildlife and Tourism is already using their Kodiak to monitor wildlife, conduct search and rescue, deliver equipment and deter poaching. With the addition of ISR capability, Botswana will be in an even better position to protect wildlife and their critically important tourism economy.

ISR stands for Intelligence, Surveillance, Reconnaissance, equipment that is bought and installed after purchase by Kodiak owners.



CAMERA



CREW



EQUIPMENT



FUEL

USEFUL LOAD = 3535 LBS  
FULL FUEL = 2144 LBS  
PAYLOAD WITH FULL FUEL = 1,391  
LOITER = 9.9 HRS





MANY MISSIONS

# EXPANDING LIFESTYLE CHOICES, MAKING POSSIBILITIES POSSIBLE.

THE KODIAK OPENS A WORLD OF NEW ADVENTURES AND NEW EXPERIENCES.

Automakers have known for decades that buyers of SUVs and light trucks are attracted to their vehicles for both heavy duty and pleasure. What works for the contractor who uses his F-150 during the week to haul supplies to the job site also works for the family trekking gear to a lakeside fishing spot.

That is the beauty of the Quest Kodiak. It is as strong and reliable as a pickup truck yet versatile enough to take the entire family and their gear to their vacation home or off to some new spot they've dreamed of visiting. Want to drop into a remote camping site. No problem. The Kodiak can land on gravel or grass while hauling all the toys. It is tough, forgiving and as safe as they come. The ability to fly in and out of remote, distant locations is enabling lifestyle choices only dreamed of before.



FAMILY: 900 LBS

+



GEAR: 500 LBS

+



FUEL: 2130 LBS

RANGE: 1005 NM TIME: 5.8 HRS



Picture courtesy Plane & Pilot.



## THE AIR SERVICE HIROSHIMA JAPAN

THE BELLA VISTA SEASIDE RESORT USES THE KODIAK TO EXTEND THEIR PREMIUM EXPERIENCE.

For luxury resorts, the challenge in creating a seamless experience has always been the so-called “last mile” — getting from the destination’s primary airport to the hotel. With a Kodiak fitted with a Summit interior, guests can be picked up at their airport as they arrive and flown directly to their hotel either by the seaplane or fixed gear airplane. This greatly extends the resort’s first class brand experience.

The exclusive Bella Vista Spa & Marina, on the Inland Sea of Japan, eliminated their “last mile” problem by utilizing Kodiak seaplanes to shuttle guests from Hiroshima Airport in 15 minutes, a trip that normally takes 90 minutes by bus. With the Kodiak’s capacity and low operating cost, the up-charge to guests is marginal, but the experience is unmatched. Guests are treated to breathtaking views of one of the most beautiful areas of Japan.

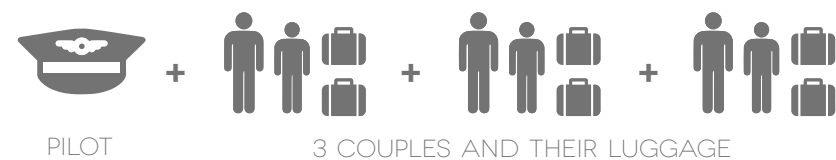

SEAPLANE'S USEFUL LOAD = 2690 LBS  
PILOT = 175 LBS COUPLES & BAGS = 1350 LBS  
PAYLOAD = 1525 LBS FUEL = 1165 LBS / 191 GAL  
RANGE@160 KTAS = 480 NM (W/RESERVES VFR)



## THE WORKHORSE ALASKA AND UTAH

A PERFECT VANTAGE POINT FOR WILDERNESS ADVENTURES AND SIGHTSEEING TOURS

With its ability to land and take off from short, unimproved strips and its bird’s eye view of wilderness vistas, the Kodiak has become a favorite for fishing, hunting and camping outfitters as well as for air tour operators. With its high useful load and plenty of room for passengers and gear, the Kodiak is the perfect platform for exploring far off the beaten path whether in the remote reaches of Alaska or in the stunning landscapes of Utah.

Redtail Air Adventures, out of Moab, Utah, uses their fleet of Kodiaks to treat guests to amazing aerial views of the Canyonlands and Monument Valley. Passengers witness rock formations, cliffs and deeply cut river valleys as few have seen. In addition, Redtail uses the Kodiak to shuttle groups for river trips or backpacking adventures. It is the all-around workhorse able to make multiple income-producing trips each day.



PAYLOAD: 1860 LBS  
FUEL: 1675 LBS / 250 GAL  
RANGE@175 KTAS = 4 HRS 26 MIN  
AND 780 NM (W/RESERVES)



Photo by Alan Discoe



## EMERGENCY AID AND AIRLIFT IN EARTHQUAKE DEVASTATED ECUADOR:

### WHAT THE KODIAK WAS DESIGNED FOR.

The Quest Kodiak is a highly versatile aircraft with amazing STOL characteristics. It is used by business, owner-operators and government for many duties, but mission one is to provide assistance to people in need. That is exactly what Samaritan's Purse (flying bulk supplies into major airports in Ecuador) and Alas de Socorro del Ecuador (ADSE), a Mission Aviation Fellowship (MAF) affiliate, have done. They flew the Quest Kodiak into the hardest to reach areas of Ecuador that were devastated by the 2016 earthquake.

The death toll from the magnitude-7.8 earthquake in a remote coastal region of Ecuador claimed an estimated 500 lives with thousands injured and homeless. According to John Woodberry, MAF Disaster Relief Manager, their "work involved more than medical transports. Because roads and bridges were destroyed by the earthquake, ADSE flights brought doctors, relief workers, medicine, and other supplies, to remote areas."

MAF, using their Kodiak, ferried in supplies and airlifted out injured people because of the remarkable short takeoff and landing capabilities of this plane. It can land and take off in less than 1000 feet fully loaded. As long as there is a reasonably safe, cleared landing strip, the Kodiak can make repeat trips into and out of the affected area carrying 7,255 lbs (or 3290 kg) of fuel, personnel and supplies.



USEFUL LOAD = 3535 LBS  
FUEL NEEDED FOR 450 NM ROUND TRIP  
(W/ IFR RESERVES): 1210 LBS / 180 GAL  
PAYLOAD AVAILABLE: 2,325 LBS

THE KODIAK CARRIES 3,535 LBS OF USEFUL LOAD AND CAN TAKE OFF AND LAND IN LESS THAN 1,000 FT. THIS PLUS ITS GENEROUS CRUISE SPEED MAKES IT THE IDEAL PLATFORM FOR AIRLIFT AND MEDIVAC OPERATIONS.

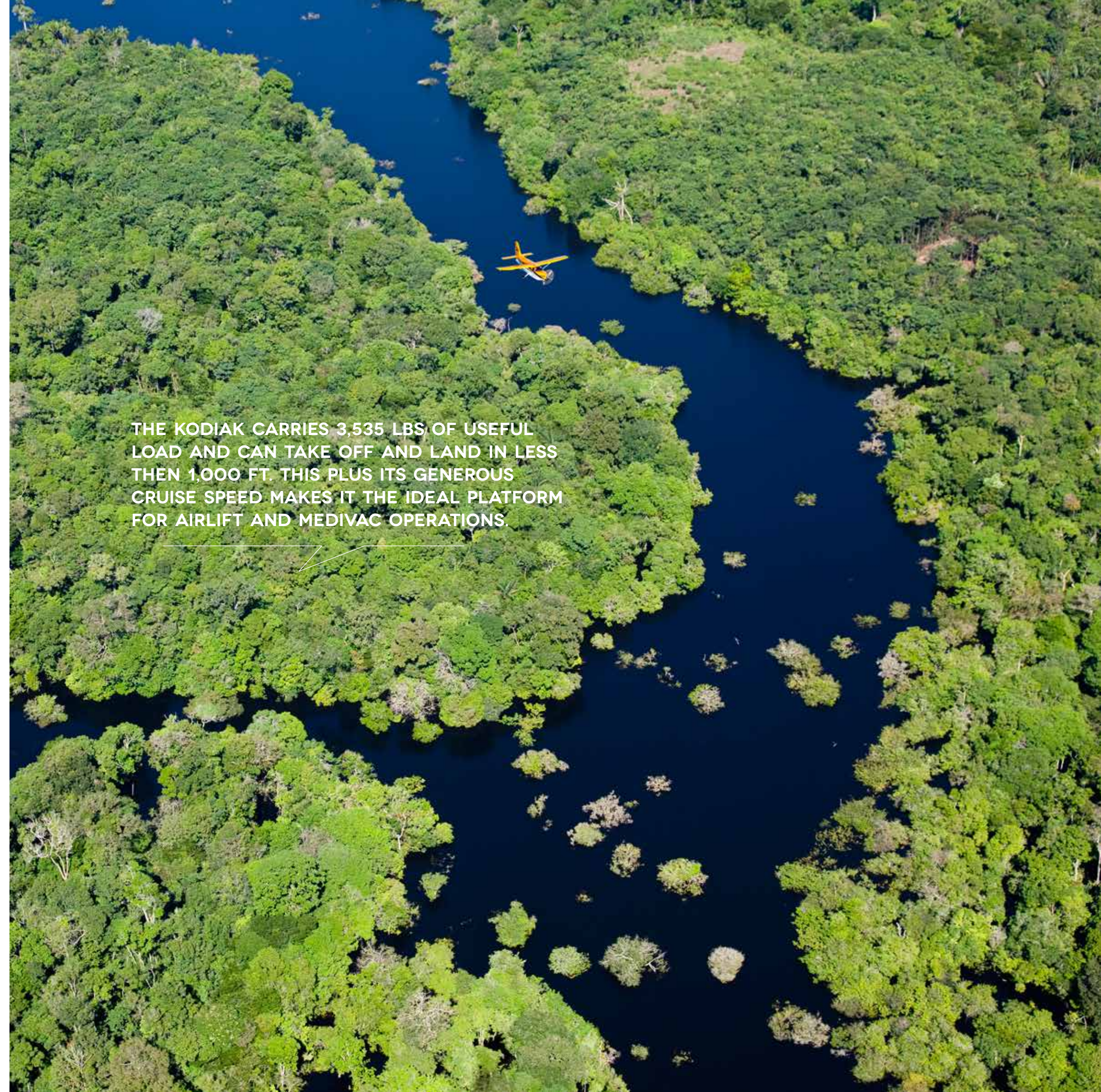

## THE GARMIN® 1000, A VISION OF SAFETY AND INTEGRATED AVIONICS

QUEST  KODIAK

TECHNOLOGY

## THE BRAINS BEHIND THE BRAWN.

To meet and exceed modern needs, multi-use operations and certification requirements throughout the world, while also remaining reliable and cost effective, Quest Aircraft has designed the Kodiak 100 with the Garmin G1000 avionics suite. Depending on your geographical location and operation, here are some enhancements you may want to consider. To adapt your Kodiak to specific needs, the following options are available:

**DATA LINK: GARMIN® GDL-69A**

From takeoff to landing, XM WX Satellite weather information boosts pilot situational awareness through interactive graphical weather updates through the G1000 MFD. Plus, receive entertainment through 170 channels of music, news, sports via the aircraft stereo intercom system.

**WEATHER RADAR: GARMIN GWX-68**

Avoid bad weather with fully integrated digital color radar. Easy to interpret and operate, this real time weather radar provides you the power to see serious weather ahead, allowing time to make safer decisions sooner.

**TRAFFIC AVOIDANCE SYSTEM: GARMIN GTS 800**

For added protection in “see and avoid” traffic situations, nothing beats this Traffic Advisory (TAS) and Traffic Collision Avoidance (TCAS 1) system. This option provides active, accurate and dynamic traffic surveillance, fully integrated into the G1000 cockpit.

**STORMSCOPE® WX-500**

Stormscope was developed to specifically detect and display thunderstorm activity by analyzing radiated signals of electrical discharge from storm cells. Fully integrated into the G1000, it

provides an accurate view of areas of storms to be avoided.

**JEPPESSEN® ENABLED CHARTVIEW**

This option brings an electronic version of Jeppesen’s extensive library of charts and airport diagrams directly to the G1000 multi-function display (MFD). Approach charts, geopolitical features, airspace, airways and airport diagrams are visually displayed. In addition pilots will see the Kodiak’s position on the chart. These electronic charts greatly reduce the amount of paper in the cockpit and help reduce pilot workload.

**ELT 406 MHZ W/GPS**

The Kodiak comes standard with, an industry leading, 406 MHz ELT with GPS capabilities, showing our commitment to building the safest product possible.

**GARMIN SEARCH & RESCUE ENABLE CARDS**

The Garmin Search and Rescue Enable feature allows for easy entry of search and rescue patterns into a flight plan. The standard enable card has three basic search patterns (Parallel, Sector, and Expanding Square) to provide step-by-step tracking procedures right in the G1000. All the patterns have customizable parameters that can be adjusted based on the object being searched, weather, and terrain. This is fully integrated into the G1000 so all the normal functions of a flight plan are incorporated (time, speed, distance, fuel remaining, etc.). The search and rescue flight plan can also be coupled to the GFC 700 autopilot allowing the pilot to be an extra set of eyes. The enhanced enable card includes all the standard features plus adds a circular search pattern.



# PRODUCT ENHANCEMENTS A LOT HAS CHANGED SINCE 2007

2008-2016



## MODERN. TOUGH. CONTINUOUSLY IMPROVED.

The Kodiak is a new airplane. Unlike competitors that were designed decades ago, the Kodiak benefits from the latest advances in engineering and technology. It was built tough and smart from the beginning, but it did not stop there . . .

The history of the Kodiak has been a story of continuous improvement and refinement. As technological improvements have been proven and come online, they have been incorporated into each new edition of the Quest product. The result is an increasingly safe, comfortable and efficient airplane.

2008/09

- > Jump Package Approved
- > Kodiak Full-motion Simulator Introduced
- > Cockpit Oxygen System Refined

2010

- > Increased Takeoff Weight
- > S-Tec 55X Autopilot Became Standard
- > Synthetic Vision Became Standard
- > Inflatable Door Seals & Sound Proofing Improvements
- > Major Electrical Enhancements with a Stall Computer, DIPS & Squat Switch Added
- > Enhancements to cargo door & corrosion prevention
- > Dual Actuator (dually redundant) Inertial Separator Added

2011

- > Improved Shimmy Damper
- > IE Fuel Flow Transducer Upgrade
- > Nose Strut & Drag Link refinement
- > Bleed Air & Cabin Improvements
- > Lower Pressure Fuel Switch

2012

- > Air Conditioning Upgrades
- > New Style Reading Light and Map Light Switch
- > New Style Cargo Door Switches
- > Terrain Awareness & Warning System (TAWS) Functionality Increased
- > Placard & Safety Improvements
- > Unnecessary Weight Removal, increasing payload
- > Environmental Control System (ECS) overhaul and update to a full digital & touch screen solution
- > Airframe Engineering Improvements for added strength and weight reduction
- > New Cabin Lighting System
- > Cockpit Ergonomics Layout Improvements
- > New Windshield Components & Refinements

2013

- > Brand New Composite Interior
- > Sun Visor Refinements & Modifications
- > Annealed Crew Door Windows
- > Improved Crew Door Steps
- > Airframe Life Extension to 10,000 hours
- > New Style Cabin Heater
- > Exterior Lighting Upgrade to high intensity & high efficiency LED/HID
- > 3" Speaker Installed in Cockpit
- > Changed Tundra Standard Interior / Includes 4 Passenger Seats as standard equipment

2014

- > Increased Landing Weight by nearly 800 lbs
- > Upgraded Cargo Door
- > Advanced Kodiak familiarization course introduced in full-motion simulator
- > WX Radar Harness Installed on all planes
- > Summit Executive Interior Added

2015

- > Garmin Auto Pilot added as standard equipment
- > Cockpit / Cabin USB Ports
- > TKS Tank in the Pod
- > Carbon Fiber Aerocet Floats Certified

2016

- > Cabin Heating Improvements
- > Bleed Air & Cabin Noise Volumes Reduced
- > Cockpit Voice & Data Recorders Added
- > Electric & Avionics Upgrades
- > ELT Standard
- > Chip Detector Std.
- > GDL69A Upgrades
- > Electrical Improvements
- > Sensor Improvements
- > Improved Oil Cooler
- > Firewall Blankets Added
- > Fatigue Life Doubled
- > Tail Stand Improvements
- > Smoked Windshield – UV Light Protection



QUEST  KODIAK

THE SEAPLANE

## THE KODIAK WITH CARBON FIBER FLOATS

NO OTHER AIRCRAFT IN THE WORLD TODAY  
MATCHES THE KODIAK'S SEAPLANE PERFORMANCE,  
EFFICIENCY, SAFETY AND COST.

The Kodiak is ready for the float installation of your choice. Designed from the outset for float operation, this seaplane can take off from water or a runway while preserving unprecedented water operation performance.

The possibilities are endless: Travel to all those out-of-the way lakes and rivers you've always longed to visit; haul hunters, fishermen or supplies to those locations that can't be reached any other way; deliver guests to seaside resorts; or, take business partners to that lakeside meeting.

Every Kodiak seaplane is corrosion-proofed both externally and internally to provide the owner with the best protection and least maintenance cost for their investment, making operations in saltwater environments no problem.

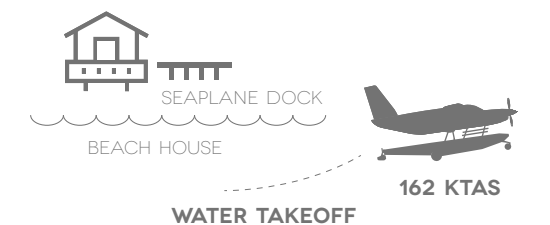

GET HOME FASTER IN A KODIAK  
FASTEST SEAPLANE CURRENTLY MADE

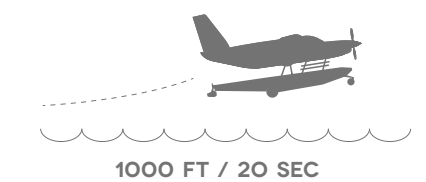

TALK TO YOUR DEALER ABOUT SEAPLANE CONVERSIONS.

THE KODIAK WAS ENGINEERED FROM THE START TO ACCEPT  
FLOATS. IT MAKES FOR ONE OF THE SAFEST, MOST EFFICIENT  
SEAPLANES ON THE MARKET.



**THE PRATT & WHITNEY PT6A TURBOPROP ENGINE OFFERS UNMATCHED PERFORMANCE, RELIABILITY AND VALUE WITH 750 SHAFT HORSEPOWER.**

**QUEST  KODIAK**  
**OPTIONS**

## CUSTOMIZABLE TO FIT YOUR NEEDS

THE KODIAK OFFERS A WIDE RANGE OF INTERIOR AND EXTERIOR OPTIONS WHICH ARE LISTED BELOW:

### EXTERIOR:

#### External Baggage Compartment

The External Baggage Compartment (ECC) installation is of composite construction and mounts onto the bottom of the fuselage to provide additional cargo and baggage space. It has a maximum load-carrying weight of 750 pounds and a maximum floor loading of 65 pounds per square foot to allow a wide variety of loading scenarios. The ECC is divided into three compartments separated by composite bulkheads and each compartment has an individual loading door and internal skid ramp to facilitate loading and unloading. With its clean aerodynamic design, there is very little reduction in performance (only 1-2 knots reduction in cruise speed).

#### TKS® Ice Protection

The TKS Ice Protection System makes the airplane Certified for Flight into Known Ice (FIKI). It incorporates porous titanium panels attached to the leading edge of the wings, wing struts, main landing gear legs, and empennage. The system includes a 16 gallon tank which yields an endurance of 2-1/2 hours of continuous operation in normal icing conditions. The tank may be refilled in flight for extended operation in icing conditions without landing. Two LED ice detection lights illuminate each wing leading edge for detection of ice at night. Windshield ice protection is provided through windshield sprayers which clears any ice build-up on the pilot's windshield. The Kodiak equipped with TKS Ice Protection is truly an all-weather airplane.

#### TKS Tank in Cargo Pod

This option moves the TKS fluid tank from the cockpit to the forward bay of the cargo pod. It holds 16 gallons and operates 2-1/2 hours under normal icing conditions. This option frees up cabin and cockpit space making it easier for the pilot to access the main cabin. The pod tank does not decrease the weight that can be inserted in the forward bay of the cargo pod and sits in front of the forward bay door, keeping the standard door size intact. The pod tank helps keep the CG forward during high load operations while taking up less than 25% of the usable volume in the forward bay.

#### 29" Tire Combo Upgrade

A popular upgrade on the Kodiak, the larger tires provide improved handling and durability on rugged back-country airstrips. This also upgrades the landing weight to 7,255 lbs. This upgrade exchanges the tires as follows:

Standard Tires: Main: 8 Ply, 8.5x10.0

Nose: 6 Ply, 6.50x8.0

Upgrade Tires: Main: 10 Ply, 29x11-10

Nose: 6 Ply, 22x8-8

### POWERPLANT:

#### Pitch Latch Propeller

For those operating the Kodiak on floats, the Pitch Latch Propeller allows the propeller to stay in a fine-pitch position when the engine is shut down. When the engine is started with the propeller blades in fine-pitch, it takes much less time to produce forward thrust and begin taxiing.

### SPECIAL OPERATIONS:

#### Turned Out Exhaust Stacks

Recommended for use with the roll down door, the turned-out exhaust stacks direct the exhaust away from the fuselage to greatly reduce the amount of exhaust fumes near the aft door.

### INTERIOR:

#### 10-Place Oxygen Upgrade

To increase the endurance of the airplane and operate at higher altitudes, this upgrade replaces the 50 cubic foot 2 place oxygen bottle with a 115 cubic foot composite oxygen bottle and adds ports for 8 passengers. Also included are 2 crew masks with built-in microphones and 8 passenger masks.

#### Air Conditioning

Controlled through a digital touch screen display which allows the pilot to select the desired temperature for the system to maintain, the vapor cycle air conditioning system consists of an engine-driven compressor, forward evaporator, aft evaporator, condenser and two blowers. Cool air is distributed throughout the cabin via twelve gaspers to generate a comfortable temperature even when it is unbearable outside



## CUSTOMER CARE IS NOT AN OPTION. IT'S A PROMISE.

WE'VE GOT YOU COVERED TIP TO TAIL, ALL WITH ONE PHONE CALL

Sandpoint is where we work; the world is where we serve. Our number one commitment is serving the worldwide community of Kodiak owners with world-class service and support. We offer a global network of Authorized Service Centers (ASCs) ready to maintain your aircraft from the first oil change. Additionally, AOG support is available 24-hours a day, 365 days a year by a team of highly dedicated, extensively knowledgeable Kodiak technicians.

### WARRANTY

Each new aircraft from Quest Aircraft comes with an industry leading warranty. Quest's warranty is designed to be seamless, worry-free, and fast to best serve our customers. With one phone call, Quest Customer Service is here to address any concerns. Additionally, our worldwide service center network will work directly with Quest to make sure

the process is smooth and our customers are getting the best service possible. Our comprehensive warranty provides coverage, in most cases, from the date of delivery to the end customer.

### FLIGHT FAMILIARIZATION

Comprehensive aircraft and systems familiarization is provided through partner organizations specializing in single engine turboprops and STOL flying. A state-of-the-art full motion Advanced Aviation Training Device (AATD) is used to simulate realistic scenarios unattainable in an actual airplane. Initial, IFR, and recurrent familiarization is offered. One initial aircraft and systems familiarization course is included with the purchase of a new Kodiak.

### MAINTENANCE TRAINING

The Quest approved Kodiak 100 Maintenance Training Course is a four-day

course. This course takes place at the factory in Sandpoint, Idaho giving students an unprecedented hands-on learning environment not offered anywhere else.

The course covers the following areas:

- Familiarization with the Kodiak 100 systems and their operation
- Basic maintenance procedures
- Garmin 1000 system functions, software and line maintenance
- Review of Kodiak 100 Service Bulletins Letters and Notifications
- Maintenance, Wiring Manual and Illustrated Parts Catalog familiarization
- Hands on projects and cockpit operational familiarization
- PT6A/Kodiak airframe interface and basic engine line maintenance procedures

On-site training courses are also available, upon request.

Quest Customer Service is available during our normal business hours Pacific Standard Time.

Phone: (208) 263-1111 Toll Free: (866) 263-1112 Fax: (208) 263-1511

Email: [customerservice@questaircraft.com](mailto:customerservice@questaircraft.com)

Technical publications available through the Quest Aircraft website at [www.QuestAircraft.com](http://www.QuestAircraft.com)







## KODIAK VS. THE OTHERS

A LONG OVERDUE ALTERNATIVE TO THE WORLD'S FLEET OF AGING STOL AIRPLANES

The Kodiak 100 was introduced to the aviation community over thirty years after its nearest competitors. It's hard to imagine, but little had changed in the 7,000 pound, 10-passenger STOL category despite major advances in aviation technology, not the least of which was a dramatic change in FAA certification rules in 2003. Our competitor's aircraft are grandfathered in under much older requirements. The Kodiak, on the other hand, is built to 21st century standards. The difference is modernity.

## COMPARISON INFORMATION

### TAKEOFF DISTANCE & CLIMB RATE

	KODIAK		COMPETITOR	
Takeoff ground roll	934 FT.	285 M	1,365 FT.	416 M
Climb rate	1,341 FPM	408 M/MIN	975 FPM	297 M/MIN
Manufacturers recommended climb speed	88 KIAS	163 KPH	104 KIAS	193 KPH
Runway length	6,000 FT.	1.83 KM	6,000 FT.	1.83 KM
Height above runway threshold after T/O	762 ft. AGL	232.3 M	429 ft. AGL	131 M

Source: OEM Pilots Op. Handbooks

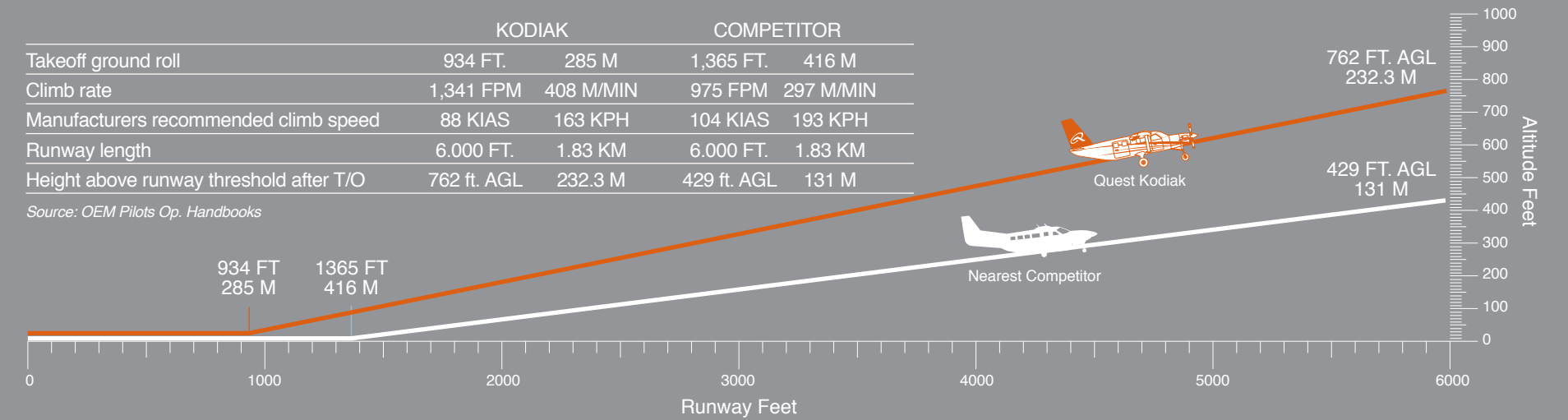

### CRUISE SPEEDS & TIME (W/ CARGO POD)

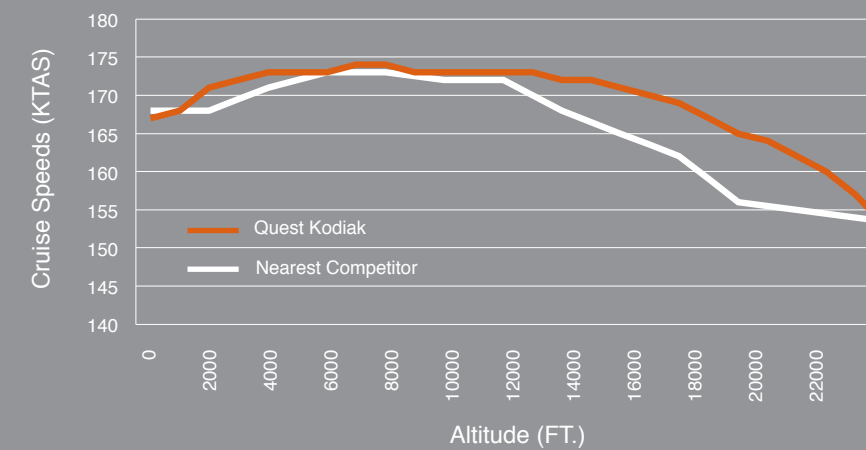

	KODIAK (173 KTAS / 320 KPH)		COMPETITOR (172 KTAS / 319 KPH)	
100 NM	0:35		0:35	
200 NM	1:09		1:10	
300 NM	1:44		1:45	
600 NM	3:28		3:29	

The Kodiak is quicker and will get you there faster.

Source: OEM Pilots Op. Handbooks

### LOADING CAPACITIES AND RANGE VS. PAYLOAD

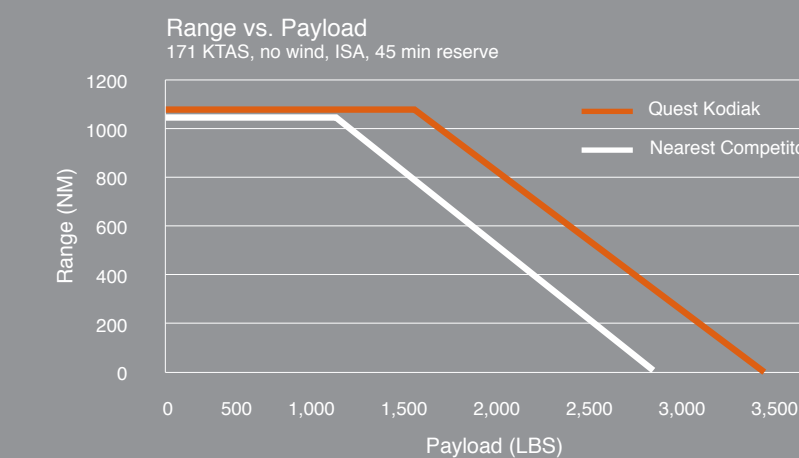
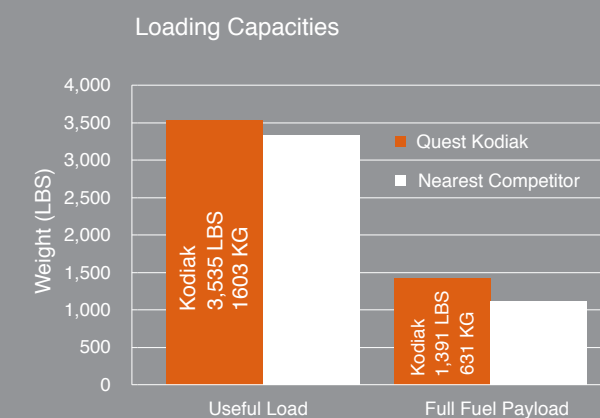

- The Kodiak has a higher useful load & more payload with full fuel
- The Kodiak can also go farther & haul more cargo at the same true airspeed (171 KTAS)

Source: Kodiak & Competitor aircraft, FAA approved, Pilots Operating Handbook



## A SMART AIRCRAFT DESIGNED AND BUILT IN THE 21ST CENTURY

### WEIGHTS & LOADINGS

Max. Ramp Weight	7,305 lbs	3,313 kg
Max. Takeoff Weight	7,255 lbs	3,290 kg
Base Aircraft Empty Weight	3,770 lbs	1,710 kg
Base Aircraft Useful Load	3,535 lbs	1,603 kg
Fuel Capacity	320 gal	1,211 L
Max. Wing Loading	30.1 lbs/sq ft	147 kg/sm
Max. Power Loading	9.67 lbs/hp	4.39 kg/hp

### PERFORMANCE (WITHOUT CARGO POD)

Stall Speed Vs1 (flaps up)	77 kcas	143 kph
Stall Speed Vs0 (flaps down)	60 kcas	111 kph
Rate of Climb (max. cont. at SL)	1,371 ft/min	418 m/min
Rate of Climb (10,000 ft)	874 ft/min	266 m/min
Takeoff Ground Roll	934 ft	285 m
Landing Ground Roll	765 ft	233 m
Certified Ceiling	25,000 ft	7,620 m

### CRUISE PERFORMANCE 183 KTAS 339 KPH

### RANGE & ENDURANCE

#### WITH 45 MIN. RESERVE (WITHOUT CARGO POD)

Max Cruise		
174 ktas, 12,000 ft (3,700 m)	1,005 nm	1,861 km
Cruise Fuel:	271 gal	5.8 hrs
Assumes consumption rate of:	48 gph	182 L/hr

Max Range Cruise		
135 ktas, 12,000 ft (3,700 m)	1,132 nm	2,096 km
Cruise Fuel:	271 gal	8.4 hrs
Assumes consumption rate of:	33 gph	125 L/hr
Max Endurance		
95 ktas, 12,000 ft (3,700m)	944 nm	1,748 km
Cruise Fuel:	271 gal	9.9 hrs
Assumes consumption rate of:	28 gph	106 L/hr

### POWERPLANT

Takeoff Power @ 2200 RPM	750 hp
Max Continuous Power	700 hp

### Propeller (Constant speed, feathering, reversible)

Diameter	96 in 2.44 m
Tip Clearance	19 in 48 cm

### FUSELAGE

Cabin Width	4'6"	1.37 m
Cabin Height	4'9"	1.45 m
Cabin Length	15'10"	4.83 m
Cargo Volume (exc. cockpit)	248 cu ft	7.02 cu m
Overall Length	34'2"	10.42 m
Seats	1-10	
Doors	3	

Door Sill Height	38 in	0.97 m
Cargo Door (LH side)		
Opening Width	49.25 in	1.25 m
Opening Height	49.25 in	1.25 m
Cockpit Doors (both sides)	31 x 51 in	
Opening Width	31 in	0.79 m
Opening Height	51 in	1.30 m

### FLIGHT SURFACES

Wing Area	240 sq ft	22.3 m
Span	45'	13.7 m
Dihedral		3°
Flap Type	Fowler, single-slotted	
Horizontal Span	20'	6 m
Overall Height	15'3"	4.48 m

### LANDING GEAR (FIXED, FAIRED LEG, NO PANTS)

Main Gear	8.5 x 10 Cleveland, spring steel
Nose Gear	6.5 x 8 Cleveland, air-oleo, steel

### CERTIFICATION

The Kodiak is certified under Part 23 of the Federal Aviation Regulations in the Normal Category for day, night, VFR, and IFR flight operations, and certified for flight into known icing when equipped with optional TKS Ice Protection System.

## CAPACITY



7,255 LBS 3,290 KG  
MAX. TAKEOFF WEIGHT

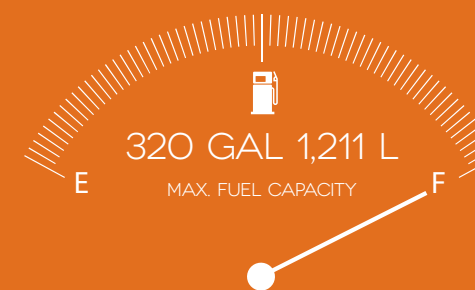
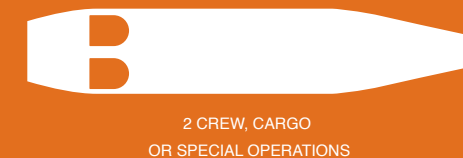
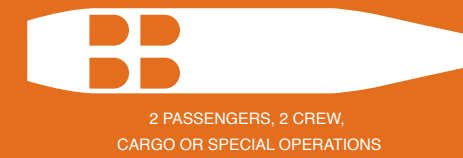

AVERAGE FUEL BURN  
45 GPH 170.3 L/HOUR

## DIMENSIONS

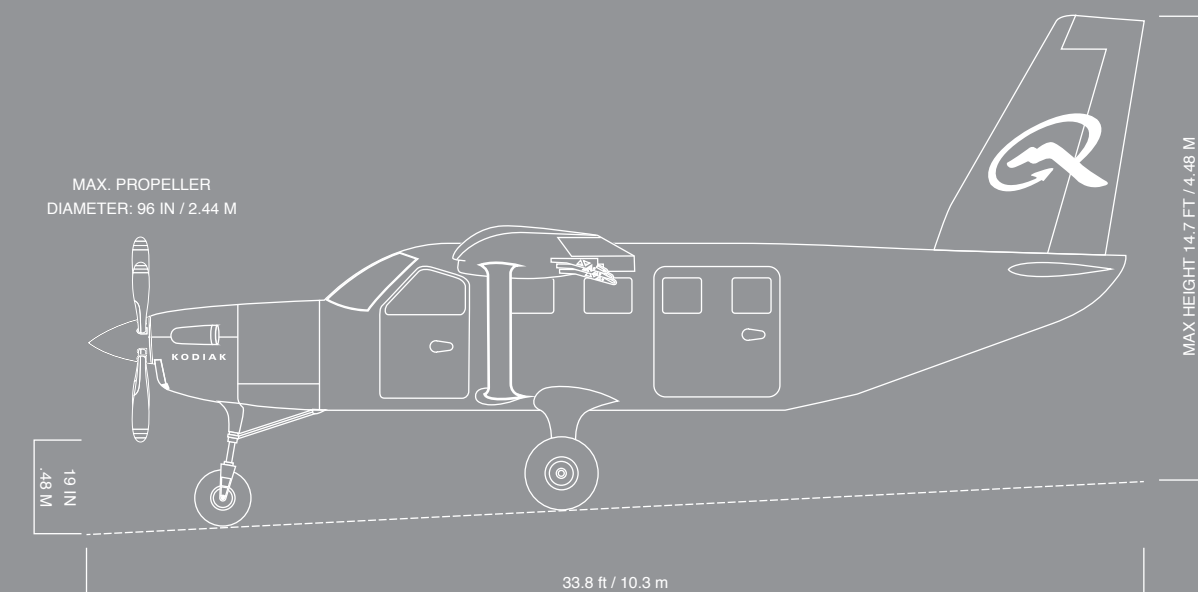
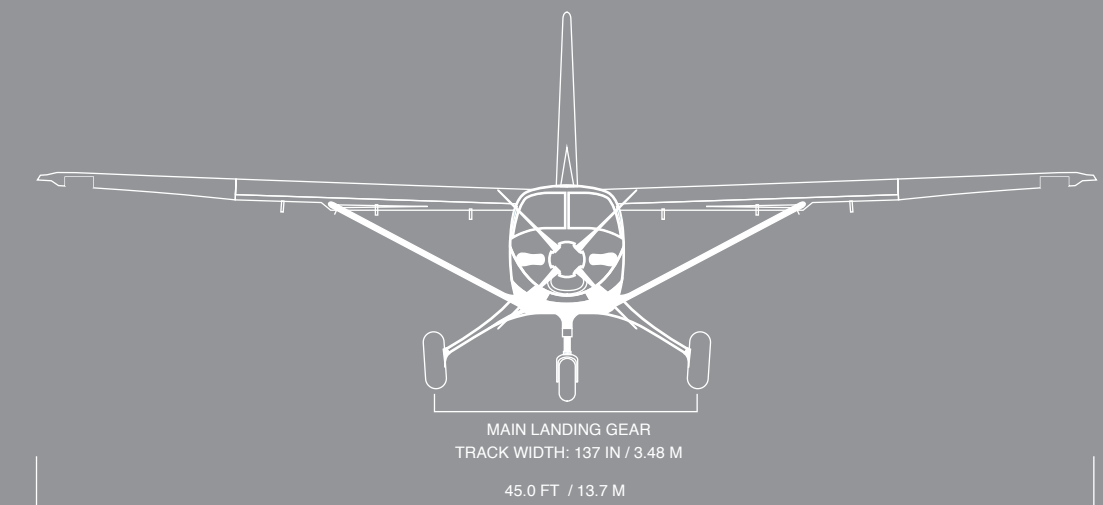
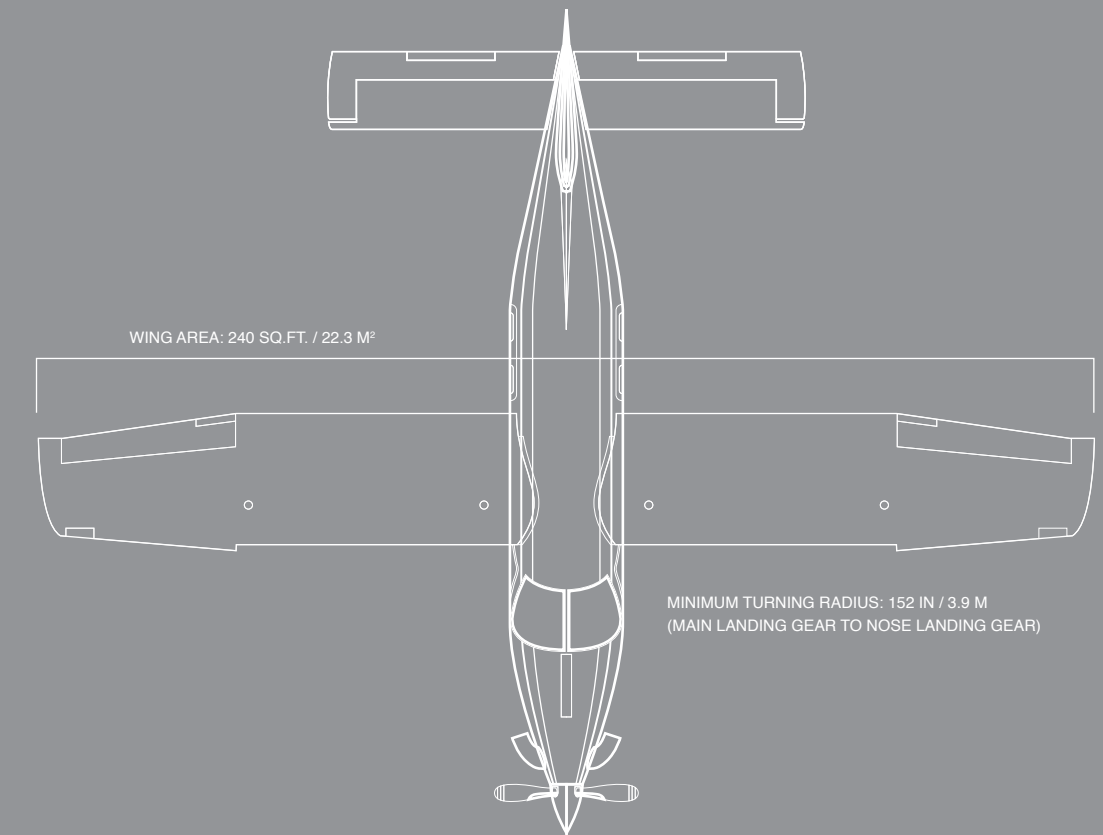



## BUILT BY A COMMUNITY FOR A MISSION SANDPOINT IDAHO

“A HOMEGROWN, LOCALLY RUN COMPANY, WITH STRONG TIES TO THE COMMUNITY AND A PASSION TO BUILD A QUALITY, ROBUST AND HIGHLY ENGINEERED AIRCRAFT.” — A QUEST ASSOCIATE.

The desire to do good and do better was at the heart of the founding of Quest Aircraft. It was the mission of providing the humanitarian community with a long overdue alternative to the world’s fleet of aging STOL airplanes that eventually lead to the creation of the Kodiak, certified in 2007 — a modern, heavy-duty plane that could deliver aid and rescue to the most remote reaches of the earth. Not an easy task given the consolidation of the aviation industry now dominated by giants.

Mission accomplished? Well, not quite.

There was a second mission: to provide employment, education and skills to rural Americans who often end up hurt by globalization. This goal was achieved by building an aircraft company from scratch in the mountains of Northern Idaho. The scenic lakeside community of Sandpoint would become the eventual home to some 250 dedicated creators of the world’s best multi-purpose short field 10-passenger turboprop.

Every member of the Quest team is committed to building a tough, safe and reliable craft, while the company is committed to giving back to their hometown. Even during their darkest times, when recession and funding were scarce, everyone did what was necessary to keep the operation going and growing. Today, with new investment partners from Japan, the company is prospering. Orders are increasing. The factory floor is expanding. The product is being continuously improved.

So, we asked our team to tell us what they think about the job they do and the product they build. Here are a few of their responses: “Quest Aircraft is a company of passionate aviators who believe in changing the status quo of OEM’s by making the best hand built, rough service, high payload plane of its class in the world,” “We take an uncompromising approach to safety and quality. We make our airplane simple to use, robust, and beautiful,” “We are loyal to our roots, and we are loyal to our customers,” and “We go where others can’t.” These are the words of maker’s pride, pride that you can feel in each Kodiak that comes out of the hangar doors.

“THE KODIAK IS LIKE A FLYING PICKUP TRUCK WITH A MUSCLE CAR ENGINE AND A LUXURY SUV INTERIOR.”





FLY IT TO BELIEVE IT

LEG 3



QUEST AIRCRAFT COMPANY  
1200 TURBINE DRIVE SANDPOINT, IDAHO 83864 USA  
208.263.1111 SALES@QUESTAIRCRAFT.COM  
WWW.QUESTAIRCRAFT.COM #QUESTKODIAK